

# 1408 CAST DUCTILE IRON COUPLINGS

## STRAIGHT AND TRANSITION PRODUCT INFORMATION

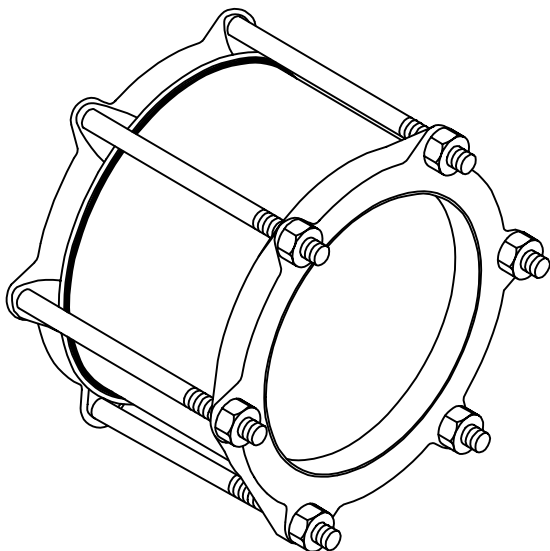

### SIZES AVAILABLE:

2" to 24" Nominal Pipe OD.

### APPLICATIONS:

**ROBAR 1408** Straight and Transition Couplings are used to make a non-restrained connection between two pipes of the same nominal size but with same or different OD's.

### MATERIAL SPECIFICATION: - COUPLING CONFORMS TO AWWA C219 - 91

Center Sleeve: Cast Ductile Iron (ASTM A536).

End Rings: Cast Ductile Iron (ASTM A536).

Gaskets: SBR (Buna S) Rubber (AWWA C111). Other compounds available.

Fasteners: 5/8" NC HSLA Steel (AWWA C111).

Coating: Two coats of Enamel.

### OTHER CAST COUPLING CONFIGURATIONS: (See Product Information for each of the following)

**1406:** Enamel coated Center Sleeve and End Rings, Stainless Steel Fasteners.

**1506:** Epoxy coated Center Sleeve and End Rings, Stainless Steel Fasteners.

**1507:** Similar to **1509** but complete with Anodes.

**1509:** Epoxy coated Center Sleeve and End Rings, Epoxy coated HSLA Steel bolts.

**1519:** Similar to **1509** but designed for cathodically protected applications.

### HOW TO ORDER:

Determine the product number (**1408**, etc.) and the high limit of range for each end of the coupling (see page 1.1.2, 1.1.3), and then use the appropriate ordering code as shown in the following example.

To couple a 6" Steel pipe (6.63" OD) to a 6" C900 PVC pipe (6.90" OD), the ordering code is:

<b>1408</b>	-	<b>6.70"</b>	x	<b>7.10"</b>
<i>product number</i>		<i>first end high limit of range</i>		<i>second end high limit of range</i>

i.e. **1408 - 6.70 x 7.10**

### ROBAR INDUSTRIES LTD.

**B.C.** Phone: (604) 591-8811 / **1-800-663-6553**  
 Fax: (604) 591-5288  
 E-mail: [waterworks@robarindustries.com](mailto:waterworks@robarindustries.com)

### LES PRODUITS INDUSTRIELS ROBAR INC.

**QUEBEC** Phone: (450) 641-9525 / **1-800-315-9525**  
 Fax: (450) 641-4894