



3406 / 3506

SEWER SADDLE



APPLICATIONS

The ROBAR Sewer Saddle allows a 4" inlet branch to be taken off the main sewer line at a 45 degree angle. Available thru 48" nominal sizes.

MATERIAL SPECIFICATIONS

Body:	Ductile Iron
Strap:	1 1/2" wide T-304 Stainless Steel, 24 gauge Fully passivated
Bolts & Nuts:	T-304 Stainless Steel Nuts coated with anti-galling compound
Gasket:	Nitrile (NBR) Rubber
Coating:	3406 – Two coats of enamel 3506 – Corrosion Protective epoxy coated

HOW TO ORDER

Determine the product number (3406), the OD of sewer main and the actual OD of the branch, then order by using the appropriate ordering code as shown in the following example.
If a 4" branch (4.50" OD) off of a 12" HDPE sewer main is required, the ordering code is:

Product Number		Main OD		Branch OD
3406	-	12.75"	x	4.50"
i.e. 3406 - 12.75 x 4.50				

MAIN SIZE (ACTUAL PIPE OD)	BRANCH SIZE (ACTUAL PIPE OD)	RUBBER BOOT SIZE (MARKINGS)	CAST BODY	STRAP LENGTH
6" – 10" (6.27" – 12.75")	4" SDR 35 (4.215")	6" – 12"	WINGED BODY (4L)	36"
	4" IPS (4.5")			
12" (12.75" – 14.40")	4" SDR 35 (4.215")	6" – 12"	STANDARD BODY (4")	48"
	4" IPS (4.5")			
14" – 24" (14.40" – 25.80")	4" SDR 35 (4.215")	14" – 48"	STANDARD BODY (4")	96"
	4" IPS (4.5")			
24" – 48" (25.80" – 54.00")	4" SDR 35 (4.215")	14" – 48"	STANDARD BODY (4")	192"
	4" IPS (4.5")			

CASTING: CAST DUCTILE IRON PER ASTM A536

SADDLE BODY: NITRILE (NBR) RUBBER PER ASTM D2000. FORMULATED WITH ANTI-FREEZING AND ANTI-OZONE AGENT

STRAP: T-304 STAINLESS STEEL, FULLY PASSIVATED. ADJUSTABLE TO ACCOMMODATE A LARGE RANGE OF PIPE SIZES

COATING: TWO COATS OF ENAMEL OR FUSION BONDED EPOXY

STAINLESS STEEL HOSE CLAMP GROOVE

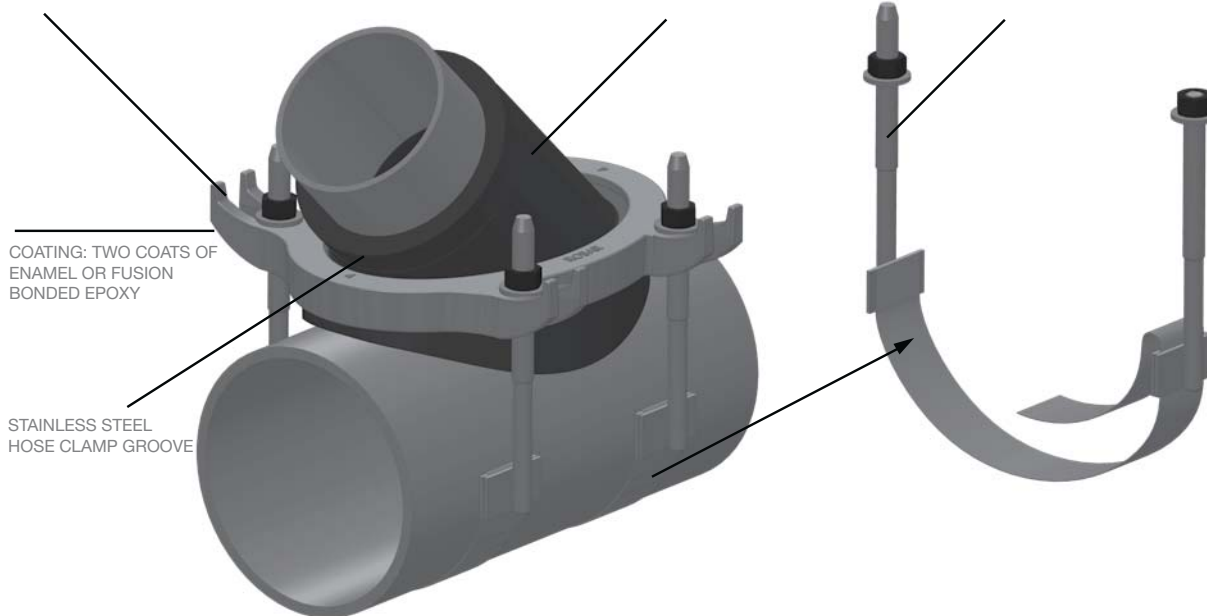

Note: Maximum 15 PSI working pressure

ROBAR INDUSTRIES LTD.

www.robarindustries.com
waterworks@robarindustries.com

Surrey, British Columbia
Phone: 1-800-663-6553

Saint-Bruno, Quebec
Phone: 1-800-315-9525