

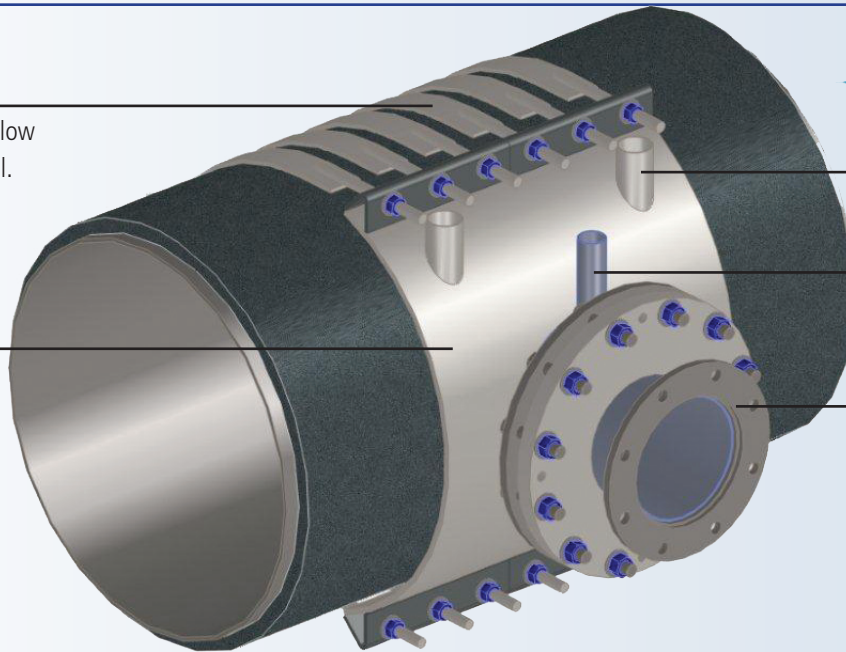

6996 TAPPING SLEEVE CONCRETE CYLINDER

High strength low alloy mild steel. Stainless Steel available.

Shell:
ASTM A36
3/8 Plate



Grout
Horns

Threaded Grout
Nipple for lifting

AWWA C207
Class D Flange

ROBAR 6996 Concrete Cylinder Pipe Tapping Sleeve complements our existing line of Tapping Sleeves. This fabricated sleeve is designed to reinforce the concrete cylinder pipe when the structural wires are cut and has the additional benefit of being able to be very easily installed.

- Capable of working to 150 psi
- Oversized outlet for easy installation
- Broad gasket for sealing over weld areas
- Reinforced outlet seal face
- Installation of load bearing screws for valve support
- Shop coated over white metal cleaning
- One central grout hole
- Tapping valve location spigot
- Requires undersize cutters

MATERIAL SPECIFICATIONS

Body:	Carbon Steel plate (ASTM A-36)
Flange:	Drilled and faced per ASA 150 lb. standards. Other drillings available. AWWA C207.
Gaskets:	NBR (Buna N) Rubber (AWWA C111).
Fasteners:	3/4" NC low alloy (AWWA C111). Torque to 75 ft. lbs. Stainless steel available.
Coating:	Two coats of enamel. Corrosion Protective Epoxy available.

waterworks@robarindustries.com

ROBAR INDUSTRIES LTD. - BRITISH COLUMBIA
Tel 604.591.8811 Toll Free 1.800.663.6553 Fax 604.591.5288

www.robarindustries.com

LES PRODUITS INDUSTRIELS ROBAR INC. - QUEBEC
Tel 450.641.9525 Toll Free 800.315.9525 Fax 450.641.4894



2996 CONCRETE CYLINDER SERVICE SADDLE

The ROBAR 2996 Service Saddles are designed for making 3/4" - 2" IP or CC taps into concrete steel cylinder pipe. The saddle is available from 16" through 36". Larger sizes available upon request. A grout opening is provided on the saddle body for restoring the concrete after the tap is complete.

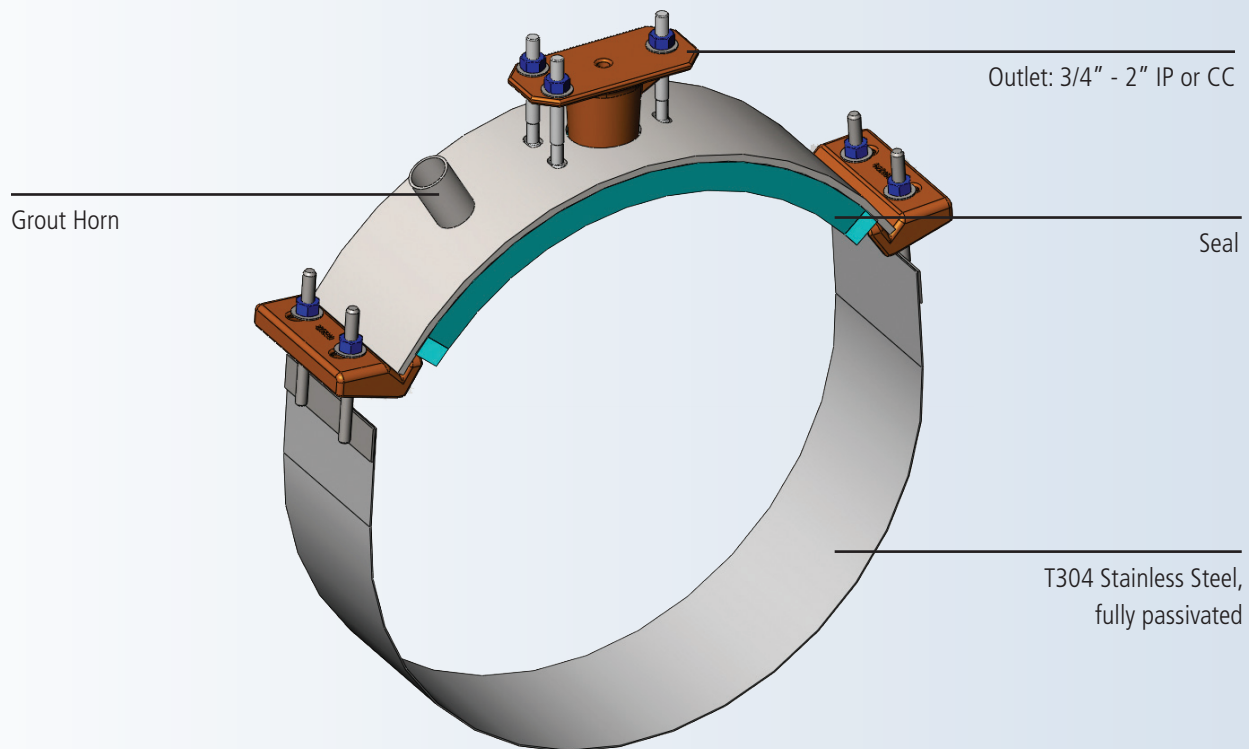

MATERIAL SPECIFICATIONS

Top Plate:	ASTM A36.
Outlet:	Cast Ductile Iron.
Strap:	T-304L Stainless Steel, fully passivated.
Fasteners:	5/8" NC T-304L Stainless Steel studs, rolled threads, nuts coated.
Coating:	Corrosion Protective Epoxy per AWWA C213